

FLASH LIGHTS



LUPINE

PIKO TL

MAXIMUM MINIMUM

Piko TL: that's maximum output at minimum size and a popular design for years.

The light and compact flashlight is made from black anodised aluminium and shines with a fabulous 1800 lumens. Piko TL is a high-tech flashlight, smaller than a smartphone and perfect for your trouser pocket.



BETTY TL 2

THE HANDHELD FLOODLIGHT

The Betty TL is your personal handheld floodlight. An easy-to-replace battery, a robust yet elegant aluminium case and a maximum output of 5800 lumens make Betty the perfect flashlight. A light yet robust aluminium case, a special lens arrangement for perfect illumination and enough output to illuminate entire valleys. The particularly powerful red light is perfect for not being immediately noticed when working in the dark. Our Betty flashlight is the absolute maximum technology can achieve.



BTL 2 PRO

HIGH POWER LED FLASHLIGHT WITH CHARGING STATION

Far away from civilisation, you want a light that delivers what it promises: Waterproof, scratch-resistant and impact-resistant, 10.4 Ah battery tank and a gigantic 5800 lumens light output. The patented orbital charging technology and the docking station provides a charging current of 1.5 A to ensure the flashlight is always full.



OVERVIEW

LAMPSETS FLASHLIGHTS

LIGHTTEST:

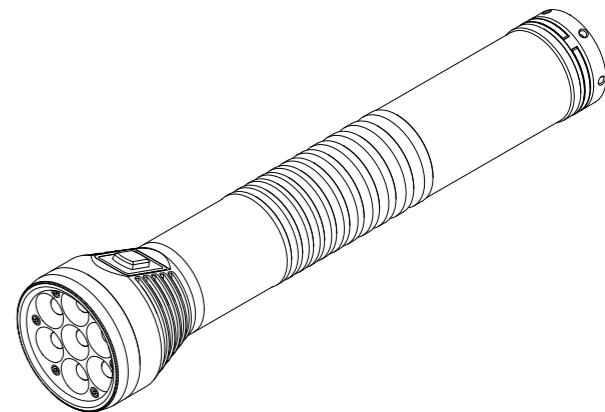
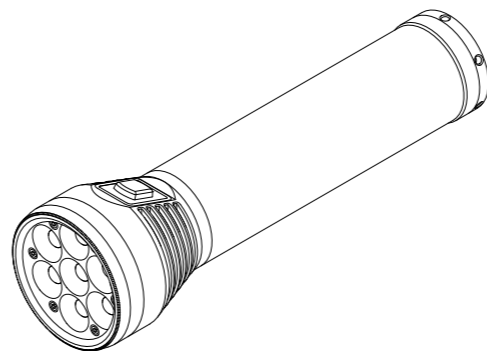
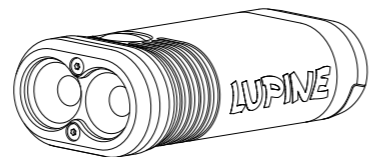

LIGHT OUTPUT
BATTERY
ACCESSORIES

SPECIAL FEATURE

LEDs
PROTECTION CLASS

PIKO TL

1800 Lumens
2.0Ah, 3.3Ah
Toolfree mount, filter,
diffuser, holster
Extremely small and bright

Cree XM-L3
IP67 / K09

BETTY TL2

5800 Lumens
3,5 Ah, 6.9Ah
1/4 inch tripod adapter,
diffuser, holster
Red Center LED

Cree XM-L3, XP-G
IP67 / K09

BTL 2 PRO

5800 Lumens
10.4Ah
Diffuser

Red Center LED,
Dockingstation
Cree XM-L3, XP-G
IP67 / K09

FORENSIC

LIGHT FOR THE TRACES

Our forensic lamps are based on the BTL2 torches. That means you can use the BTL2s you may already have, or combine a battery pack with several lamp heads. Thanks to various LEDs and filters, we offer the following wavelengths:

UV	365 NM
PURPLE	415 NM
ROYAL BLUE	450 NM
GREEN	505 NM



Lupine Lighting Systems GmbH
In Zwiesel 9
92318 Neumarkt
GERMANY

Phone: +49 (0) 9181 50 949 - 0
E-Mail: info@lupine.de
www.lupine.de